

# SUPERSIXEVO

## Owner's Manual Supplement



### **WARNING**

**READ THIS SUPPLEMENT AND YOUR  
CANNONDALE BICYCLE OWNER'S MANUAL.**  
Both contain important safety information. Keep  
both for future reference.

## Safety Messages

In this supplement, particularly important information is presented in the following ways:



### **WARNING**

Indicates a hazardous situation which, if not avoided, may result in death or serious injury.

### **NOTICE**

Indicates special precautions that must be taken to avoid damage.

The following symbols are used in this manual:

Symbol	Name	Description
	NGLI-2 synthetic grease	Apply NGLI-2 synthetic grease.
	Carbon gel	Apply carbon gel (friction paste) KF115/
	Medium-strength removable thread lock	Apply Loctite® 242 (blue) or equivalent.

## Cannondale Supplements

This manual is a “supplement” to your [Cannondale Bicycle Owner’s Manual](#).

This supplement provides additional and important model specific safety, maintenance, and technical information. It may be one of several important manuals/supplements for your bike; obtain and read all of them.

Please contact your Authorized Cannondale Dealer immediately if you need a manual or supplement, or have a question about your bike. You may also contact us using the appropriate country/region/location information.

You can download Adobe Acrobat PDF versions of any manual/supplement from our website: <http://www.cannondale.com>.

## Contacting Cannondale

### Cannondale USA

Cycling Sports Group, Inc.  
1 Cannondale Way, Wilton CT, 06897, USA  
1-800-726-BIKE (2453)

### Cycling Sports Group Europe B.V

Mail: Postbus 5100  
Visits: Hanzepoort 27  
7570 GC, OLDEENZAAL, Netherlands  
Tel: +41 61 551 14 80  
Fax: +31 54 151 42 40

### International Distributors

Consult our website to identify the appropriate Cannondale Dealer for your region.

## CONTENTS

<b>Safety Information .....</b>	<b>2-5</b>
<b>Technical Information .....</b>	<b>6-19</b>
<b>Replacement Parts.....</b>	<b>20</b>

## Your Cannondale Dealer

To make sure your bike is serviced and maintained correctly, and that you protect applicable warranties, please coordinate all service and maintenance through your Authorized Cannondale Dealer.

### NOTICE

Unauthorized service, maintenance, or repair parts can result in serious damage and void your warranty.

## SAFETY INFORMATION

### Important Composites Message

#### WARNING

Your bike (frame and components) is made from composite materials also known as “carbon fiber.”

All riders must understand a fundamental reality of composites. Composite materials constructed of carbon fibers are strong and light, but when crashed or overloaded, carbon fibers do not bend, they break.

For your safety, as you own and use the bike, you must follow proper service, maintenance, and inspection of all the composites (frame, stem, fork, handlebar, seat post, etc.) Ask your Cannondale Dealer for help.

We urge you to read PART II, Section D. “Inspect For Safety” in your [Cannondale Bicycle Owner's Manual](#) BEFORE you ride.

**You can be severely injured, paralyzed or killed in an accident if you ignore this warning.**

### Inspection & Crash Damage Of Carbon Frames/Forks

#### WARNING

#### **After A Crash Or Impact:**

Inspect frame carefully for damage. See PART II, Section D. Inspect For Safety in your [Cannondale Bicycle Owner's Manual](#).

Do not ride your bike if you see any sign of damage, such as broken, splintered, or delaminated carbon fiber.

#### **Any of the following may indicate a delamination or damage:**

- An unusual or strange feel to the frame
- Carbon which has a soft feel or altered shape
- Creaking or other unexplained noises,
- Visible cracks, a white or milky color present in carbon fiber section

**Continuing to ride a damaged frame increases the chances of frame failure, with the possibility of injury or death of the rider.**

## Intended Use

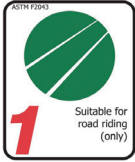

The intended use of all models is ASTM CONDITION 1, High-Performance Road.

### WARNING

Please read your [Cannondale Bicycle Owner's Manual](#) for more information about Intended Use and Conditions 1-5.

## Servicing

### WARNING

**This supplement may include procedures beyond the scope of general mechanical aptitude.**

Special tools, skills, and knowledge may be required. Improper mechanical work increases the risk of an accident. Any bicycle accident has risk of serious injury, paralysis or death.

**To minimize risk we strongly recommend that owners always have mechanical work done by an Authorized Cannondale Dealer.**

## Disc Brakes on Road Bikes

### WARNING

Relative to conventional rim brakes, disc brakes are less affected by water, do not wear or heat the rims and therefore are more consistent. Disc brakes also may be more powerful.

**To minimize risk of injury or accidents:**

- Understand that road bikes have a relatively small tire contact patch (part of the tire that touches the road). In order to apply the brakes safely and effectively, you may need more or less braking force in different situations. You need to take into account various road and weather conditions that can affect traction.
- Disc brakes are excellent, but not some kind of magic. Take some time riding your new disc brake road bike in lower risk circumstances to get used to the feel and performance of the disc brakes and tires.

**You can be severely injured, paralyzed or killed in an accident if you ignore this message.**

## Trainers

If you ride a trainer that requires removal of the front wheel and clamps the fork dropouts: Be sure your fork quick release is tight! Relative movement will wear parts, weaken and damage your bike.

If you ride a trainer that holds the bike up by clamping the rear quick release between two cones: Take off the lightweight quick release that came with your bike. Substitute a heavy, classic all steel quick release and clamp it tight! Relative movement will wear parts, weaken and damage your bike. Note that many modern quick releases will not fit the clamping cones in this kind of trainer because their shapes are incompatible.

For thru axles, make sure you follow the trainer manufacturer instructions for the use of any required adapters.

Be particularly cautious with a carbon frame or fork. Carbon is relatively soft, not abrasion resistant. If there is any relative movement, carbon will wear quickly.

If you ride a trainer a lot, consider using an old bike: Corrosion from sweat will take its toll. Weight is irrelevant. Save wear on your expensive components.

Ask your dealer for help with trainers, the right one and the correct way to use it.

### NOTICE

**TRAINERS** - Improperly mounting a bike in a trainer, or using one that is not compatible with your particular bike frame can cause serious damage.

**WATER BOTTLES** - An impact, crash, or loose bottle cage can result in damage to your frame.

These kinds of damage is not covered by the Cannondale Limited Warranty.

## Water Bottles

Side impacts to a water bottle or cage can result in damage to threaded inserts due to the leverage on a very small area. In a crash, certainly the last thing you should be worried about is saving the threaded inserts in your frame. However, when you are storing or transporting your bike, take steps to prevent situations where a water bottle may be hit or bumped by a strong force that would cause damage. Remove bottle and cage when you are packing your bike for travel.

Periodically check the attachment of the bottle cage; tighten the cage bolts if necessary. Don't ride with a loose bottle cage. Riding with loose cage bolts can produce a rocking motion or vibration of the attached cage. A loose cage will damage the insert and possibly lead to the inserts to pull out.

It may be possible to repair a loose insert, or install another insert only if the frame is undamaged. Replacement requires the use of a special tool. If you notice damage to the threaded insert, please ask your Cannondale Dealer for help.

## Building Up A Frame Set

Before building up a frame set, consult with your Cannondale Dealer and the component manufacturers, and discuss your riding style, ability, weight, and interest in and patience for maintenance.

Make sure the components chosen are compatible with your bike and intended for your weight and riding style.

Generally speaking, lighter weight components have shorter lives. In selecting lightweight components, you are making a trade-off, favoring the higher performance that comes with less weight over longevity. If you choose more lightweight components, you must inspect them more frequently. If you are a heavier rider or have a rough, abusive or "go for it" riding style, buy heavy duty components.

Read and follow the component manufacturers warnings and instructions.

## Tightening Torques

Correct tightening torque for the fasteners (bolts, screws, nuts) on your bicycle is very important to your safety. Correct tightening torque for the fasteners is also important for the durability and performance of your bicycle. We urge you to have your dealer correctly torque all fasteners using a torque wrench. If you decide to torque fasteners yourself always use a torque wrench.

### Find Tightening Torque Information :

The wide range of bicycle models and components used means that a listing of tightening torque would be out of date by the time it was published. Many fasteners should be installed with a thread locking adhesive such as Loctite®.

#### **To determine correct tightening torque and any adhesive application for a fastener we ask you to check:**

- Many components are marked. On-product marking is becoming common.
- Torque specs in the component manufacturers instructions shipped with your bicycle.
- Torque specs listed on the websites of component manufacturers.
- With your dealer. Dealers have access to current data and have experience with correct torque for most fasteners.

## TECHNICAL INFORMATION

### Frame Specifications

#### SuperSix Evo HM/Carbon Disc

Item	Specification
Head Tube	Sizes 44-54 cm: UPR: 1-1/8 in, LWR: 1-1/4 in Sizes 56-62 cm: UPR: 1-1/8 in, LWR: 1-3/8 in
Headset	Sizes 44-54 cm: Integrated, 1-1/8 in - 1-1/4 in Sizes 56-62 cm: Integrated, 1-1/8 in - 1-3/8 in
Bottom Bracket: Type/Width	PF30A / 73 mm
Front Derailleur	Brazed-on
Seat Post: Dia./Binder	HG/HGSL 27 KNOT / Internal Wedge
▲ Min. Seat Post Insert	65 mm
▲ Max. Seat Post Insert	44cm-140 mm, 48 cm - 179 mm, 51-62 cm (measure)
▲ Tire Size x Max. Width	700c x 30 mm (measured)
Fork Maximum Turning Angle	+/- 55°
Brakes: Mount Type / Min/Max Rotor Dia.	RR: Flat Mount / 140 mm / 160 mm FT: Flat Mount / 140 mm / 160 mm
Axles: Type / Hub Spacing / Length	RR: Speed Release TA Double Lead / 142 × 12 mm / 165 mm FT: Speed Release TA Double Lead / 100 × 12 mm / 119 mm"
▲ Intended Use:	ASTM Condition 1
▲ Max. Weight Limit: Total (rider+all equipment)	285 lbs / 129 kg



## SuperSix Evo Carbon Rim

Item	Specification
Head Tube	Sizes 44-54 cm: UPR: 1-1/8 in, LWR: 1-1/4 in Sizes 56-62 cm: UPR: 1-1/8 in, LWR: 1-3/8 in
Headset	Sizes 44-54 cm: Integrated, 1-1/8 in - 1-1/4 in Sizes 56-62 cm: Integrated, 1-1/8 in - 1-3/8 in
Bottom Bracket: Type/Width	PF30A / 73 mm
Front Derailleur	Brazed-on
Seat Post: Dia./Binder	HG/HGSL 27 KNOT / Internal Wedge
▲ Min. Seat Post Insert	65 mm
▲ Max. Seat Post Insert	44cm-140 mm, 48cm - 179 mm, 51-62cm (measure)
▲ Tire Size x Max. Width	700c x 28 mm (measured)
Fork Maximum Turning Angle	+/- 55°
Brakes: Mount Type / Min/Max Rotor Dia.	Direct Mount Rim Brakes
Axles: Type / Hub Spacing / Length	RR: QR / 130 x 10 mm FT: QR / 100 x 9 mm
▲ Intended Use:	ASTM Condition 1
▲ Max. Weight Limit: Total (rider+all equipment)	285 lbs / 129 kg

## Serial Number

The serial number is located on the bottom bracket. It is a 7-character barcode (1). Use this serial number to register your bike.

To register your bike: go to the **Product Registration** section of our website at [www.cannondale.com](http://www.cannondale.com)

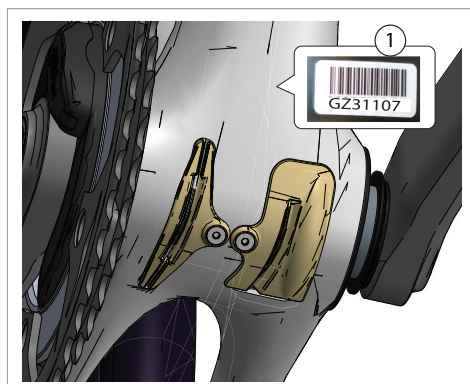

### Geometry

- A Seat Tube Length
- B Top Tube Horizontal
- D Head Tube Angle
- E Seat Tube Angle
- G Head Tube Length
- H Wheelbase
- I Front Center
- J Chain Stay Length
- K Bottom Bracket Drop
- L Bottom Bracket Height
- M Fork Rake
- N Trail
- O Stack
- P Reach

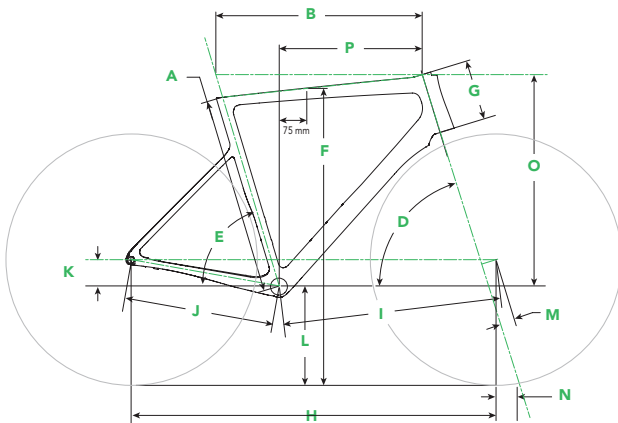

Dimensions = centimeter/inches

Size	44	48	51	54	56	58	60	62
A	40.0/15.7	43.8/17.2	47.7/18.8	51.5/20.3	53.6/21.1	55.8/22.0	57.9/22.8	60.0/23.6
B	51.2/20.2	52.0/20.5	52.8/20.8	54.6/21.5	56.2/22.1	57.8/22.8	59.4/23.4	61.1/24.1
D	70.9°	71.2°	*	*	73.0°	*	*	*
E	74.3°	*	*	73.7°	73.3°	72.9°	72.5°	72.1°
G	9.9/3.9	11.4/4.5	13.0/5.1	15.3/6.0	16.4/6.5	18.8/7.4	20.9/8.2	23.0/9.1
H	97.9/38.5	98.5/38.8	99.4/39.1	100.8/39.7	99.2/39.1	100.5/39.6	101.6/40.0	102.8/40.5
I	58.2/22.9	58.8/23.2	59.7/23.5	61.1/24.0	59.5/23.4	60.7/23.9	61.8/24.3	63.0/24.8
J	40.8/16.1	*	*	*	*	*	*	*
K	7.4/2.9	*	*	7.2/2.8	*	6.9/2.7	*	*
L	26.8/10.6	*	*	27.1/10.6	*	27.3/10.7	*	*
M	5.5/2.2	*	*	*	4.5/1.8	*	*	*
N	6.0/2.4	5.8/2.3	*	*	5.8/2.3	*	*	*
O	50.4/19.8	51.9/20.4	53.4/21.0	55.4/21.8	57.4/22.6	59.4/23.4	61.4/24.2	63.4/25.0
P	37.0/14.6	37.4/14.7	37.8/14.9	38.4/15.1	39.0/15.3	39.5/15.6	40.0/15.8	40.6/16.0

\* Indicates same.

All Specifications subject to change without notice.

## Bottom Bracket - PF30A / 73 mm

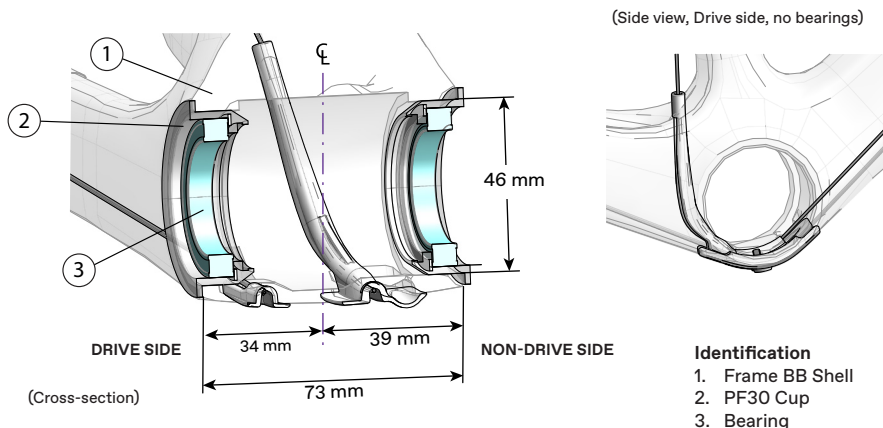

### Maintenance

Have the bearings inspected annually, anytime the crankset is removed, or if a problem is indicated.

With crankset removed, rotate the inner bearing race of both bearings; rotation should be smooth and quiet. Excessive play, roughness, or corrosion indicates a damaged bearing.

### Replacement

Bearings are not removable from the PF30 cup systems pressed into the bottom bracket shell. Therefore, both bearing and cup must be removed together replaced as a new set.

Before installing any new bearing units into the shell, thoroughly clean the inside surface of the bottom bracket shell with a clean dry shop towel. Also, make sure both bearing units and the BB shell surfaces are clean and dry. Do not apply grease.

To avoid serious damage to the frame, it is important to remove bearing systems very carefully using proper tools indicated by the manufacturer's service instructions. Make sure the bearings (cup or adapter parts) are driven out squarely and evenly from inside the shell! Do not pry components from shell.

Follow the manufacturer's instruction for assembly and installation of the bearing system. Use a headset press such as Park Tool HHP-2. See <http://www.parktool.com/product/bearing-cup-press-HHP-2>.

Select appropriate press and adapters to ensure that force is only applied to the cup and not the bearing inside. Press until both cup flanges are mated to the BB shell edge.

### NOTICE

- Consult with your Cannondale Dealer on the quality and compatibility of any proposed replacement component.
- Do not use chemical solvents to clean. Do not remove frame material or use surfacing tools on bottom bracket shell.
- Frame damage, caused by improper components, component installation or removal is not covered by your warranty.

## DT Port Guides / Routing

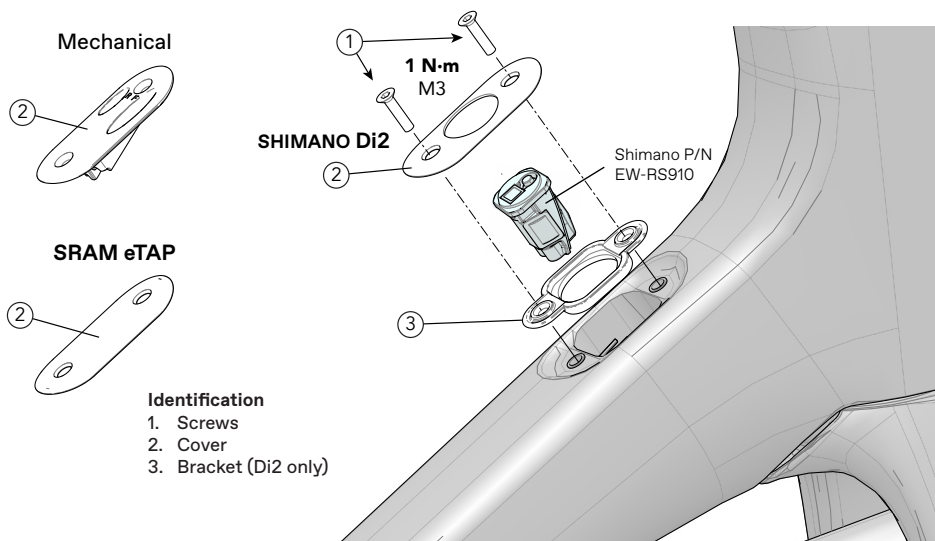

## BB Cable Guides / Routing

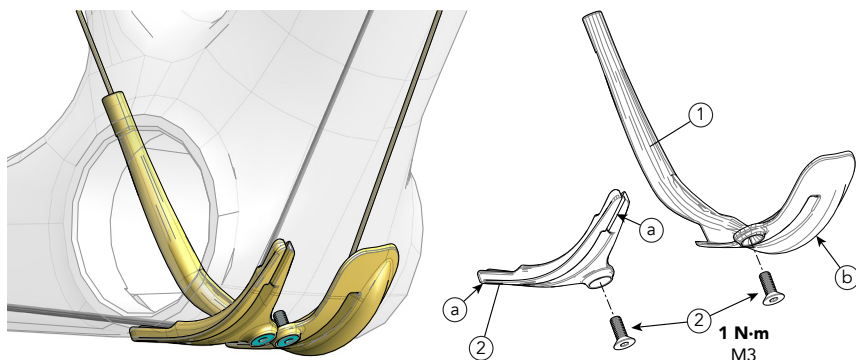

The interior of the BB Shell is to remain free of any cable, housing or wires passing through it. These items must be captured by the cable guides as they emerge from the downtube and exit to the chainstays and seat tube.

Please Note: Note Di2 cables must not touch the spindle. Use a BB bearing assembly with a sleeve between the bearings to protect the spindle from wear due to cables touching it.

### Identification

1. FD cable & rear disc brake guide.
  2. RD cable & di2 cable
  3. Screws
- a. Slot for Di2 cable(s).
- b. Rear brake housing trough

## Rear Derailleur Mount

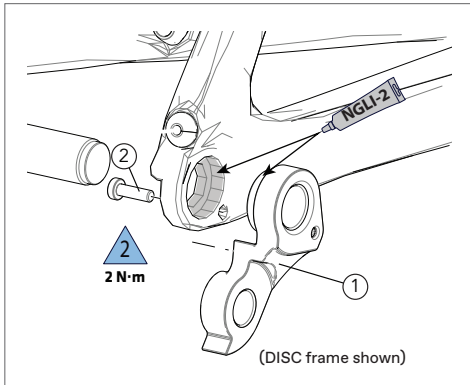

1. RD Mount
2. Screw

### To replace:

Remove the rear axle.

Remove the mounting screw(s) and remove the old hanger from the dropout. Clean the area around the dropout and inspect the frame carefully for any cracks or damage. If you find damage have the frame inspected by your Cannondale Dealer .

If the dropout is un-damaged, apply a light film of grease between the frame and mount. This will help minimize any noise or “creaking” that might result from very slight movement between the dropout and mount during movement of the derailleur.

Slide the new hanger onto the dropout. Apply Loctite® 242 (or medium strength thread lock) to the screw threads and tighten to the specified torque.

## Front Derailleur Mount

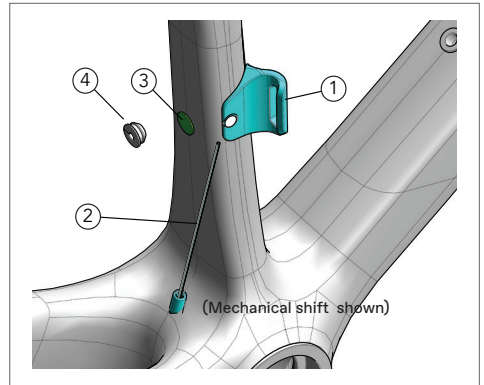

1. FD Mount
2. FD cable
3. Frame Plug
4. Di2 Cable Plug

The front derailleur mount is bonded to the frame. It is a “braze-on type.”

Do not attempt to remove the mount.

When using a mechanical FD system or SRAM Etap, make sure the frame plug is installed to prevent the intrusion of water or debris into the frame.

When using Di2 Systems, use the Di2 Cable Plug.

## Headtube Steering Angle

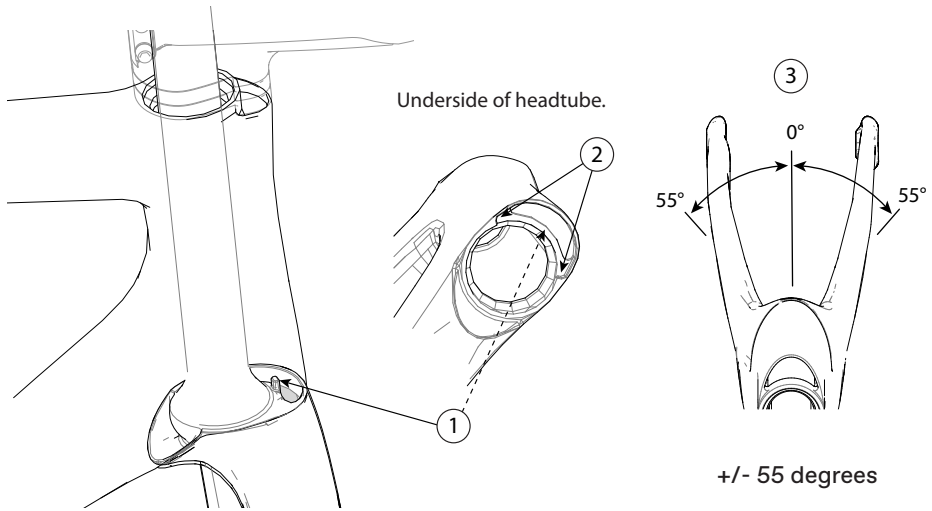

### NOTICE

Do not force the steering past the stop points.

If the front end steering of the bikes is overloaded (due to e.g. a handlebar strike, a crash, etc.) damage to the frame, fork or pin may result.

This type of damage is not covered by the limited warranty.

### Identification

1. Fork Stop Pin (molded)
2. Head Tube Stop Limits (molded)
3. Steering Angle

## Rear Brake Bridge Assy - RIM

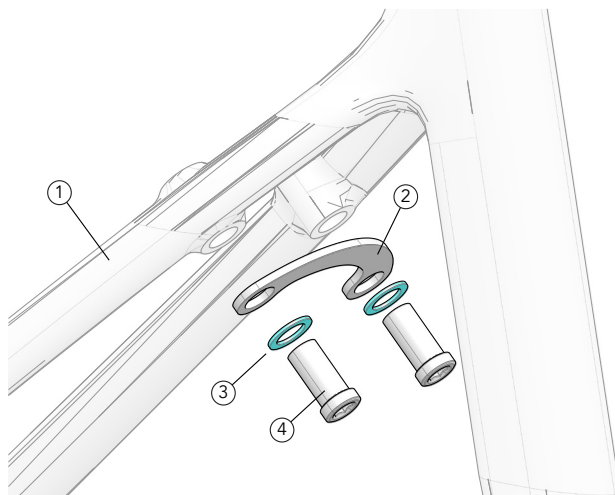

### Rear Brake Bridge

The rear brake bridge assembly parts are required to be used.

These parts provide necessary support to the frame and ensure that braking force is not absorbed by movement of the frame.

The parts are to be installed on the underside of the seatstays at the frame bosses as shown.

Do not adapt or modify the frame or the bridge parts in any way.

Follow the instruction provided by the brake manufacturer when installing brake.

### **WARNING**

Do not ride without a rear brake system installed.

Do not omit or remove the rear brake bridge parts.

#### Identification

1. Seat Stays
2. Brake Bridge
3. Washer (2X)
4. Nuts (2X)

## Seat Post

### Installation & Adjustment

#### Before installing:

- Use a clean shop towel to wipe out any residual carbon gel paste from the inside the seat tube.
- Apply fresh carbon friction gel to the seat post and place a little bit inside the seat tube.
- Make sure the seal is in good condition and in place on the seat post.

#### To adjust:

1. Insert the prepared seat post into the frame. Maintain the specified minimum insert.
2. Set the saddle height.
3. Insert 4 mm hex through the underside seat tube opening as shown.
4. Tighten the binder screw to the specified torque.
5. Slide the seal against the frame.
5. If the saddle angle adjustment is required, loosen the saddle clamp bolts, adjust the saddle, and tighten to the specified torque.

#### NOTICE

- Do not use any spray cleaners or solvents to clean. Use only a clean dry shop towel.
- Do not exceed the specified torque. If you over-tighten the binder bolt, you will damage the binder, seat post or the frame.

### Maintenance

Periodically, remove the seat post and the clamp assembly to clean, inspect for damage and renew the application of grease and carbon gel.

See also, "Seat Binder Inspection."

### Minimum Insert

The minimum insert depth the seat post must be inserted into the frame is 65mm.

### Maximum Insert

The total length of seat post that may be inserted will vary with the frame size and should be checked in each frame.

To check, carefully slide a seat post into the frame until it stops; then lift it up 5mm.

#### NOTICE

A seat post should not be bottomed out inside the frame at any time. Have your Cannondale Dealer size the seat post appropriately.



#### WARNING

**THE SEAT POST MUST ONLY BE CUT BY A PROFESSIONAL BIKE MECHANIC.** Incorrectly cutting the seat post can result in damage leading to an accident.

For more information about carbon fiber seat posts, see also "Care and Maintenance of Carbon Fiber Seat Posts" in your Cannondale Bicycle Owner's Manual.



## Identification

1. Saddle Clamp
2. Seat Post
3. Sliding Clamp
4. Seal
5. Di2 Battery
6. Battery Bracket
7. Di2 Cable

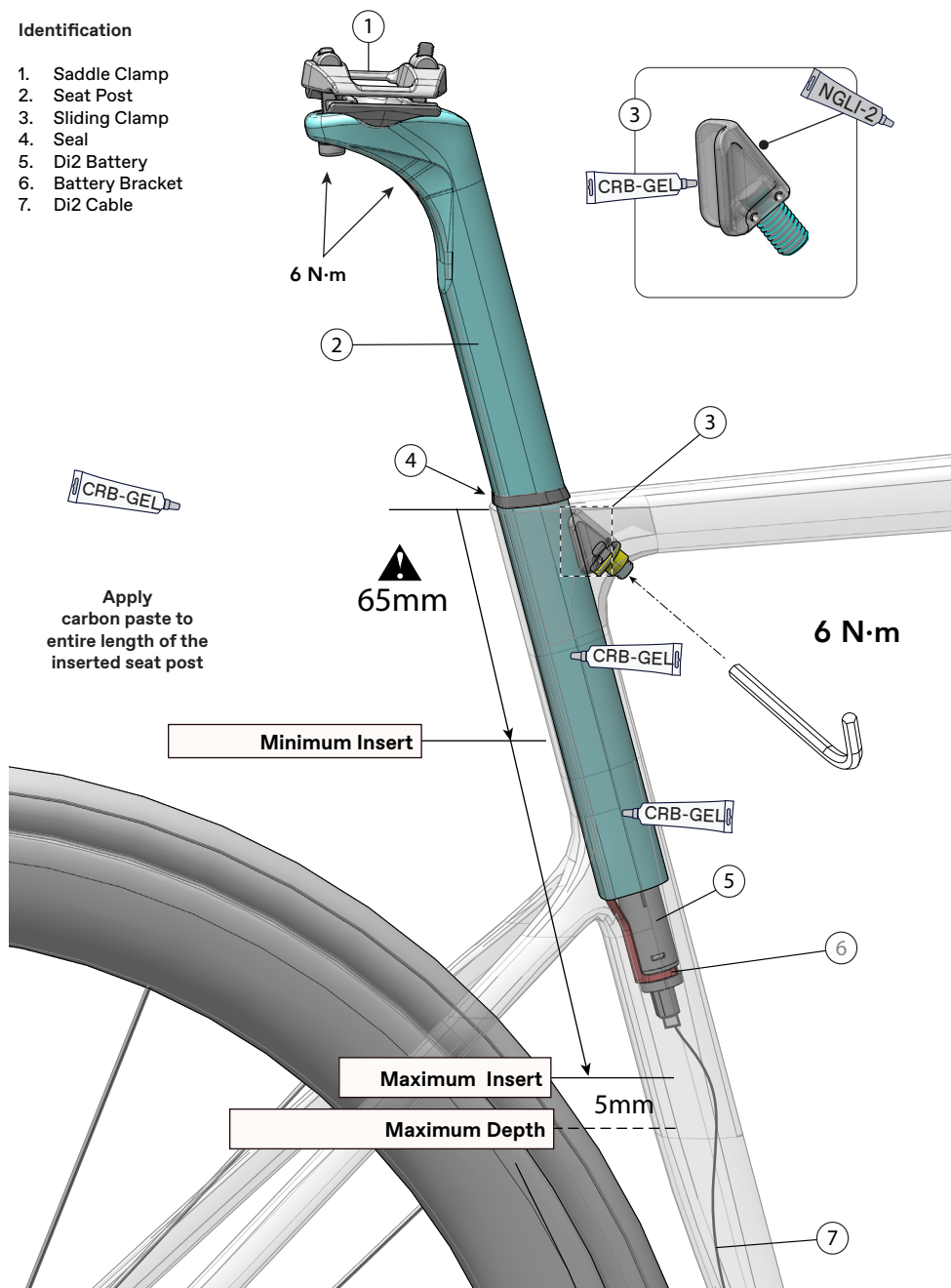

### Seat Binder Inspection

The internal seat binder system consists of a sliding clamp assembly and a nut base with a double-side adhesive holding it to a special mating surface inside the seat tube. The sliding clamp parts can be removed when the seat post is out.

Always clean the surfaces of the sliding clamp by wiping them with a clean dry lint-free shop towel only. Do not soak the parts, as the internal washer is lubricated with grease. Solvents will wash out the lubricant and the assembly will have to be regreased by disassembling it completely.

#### NOTICE

If the nut base has become rotated, it should be removed and re-affixed to the frame. The process is described in the Service Instruction for the parts kit. These instructions are not provided in this manual. We recommend that you have a Cannondale Dealer perform the replacement.

**Please Note:** During first assembly of the nut base, it is important to not push on the 4mm allen when tightening onto the seatpost. This can disengage the adhesive tape before proper bonding. A poor bond can lead to misalignment. The 3M™ VHB™ Tape 5980 is pressure sensitive.

---

#### To inspect

1. To remove the seat post. See previous page.
2. To remove the sliding clamp, use a 4 mm hex key and turn grub screw slowly clockwise until the clamp is disengaged from the nut base.
3. Use the 4 mm hex to push the clamp out through the seat tube opening.
4. Look into the frame opening. Use a pen flashlight. Check the position of the nut base. See CORRECT next page.
5. If the nut base is missing, or rotated or damaged, a replacement is required. This service should be performed by a Cannondale Dealer.
6. Check the condition of the clamp. The seat post face and frame contact surfaces should be smooth. If they are not, the clamp assembly should be replaced with a new one.
7. Clean the parts and inside the seat tube with a dry shop towel and re-apply grease and carbon paste as indicated.
8. Returning the sliding clamp to the frame, using the 4 mm hex to guide it to the nut base.
9. Turn the grub screw counter-clockwise to engage the nut base. Make sure it is engaged sufficiently to easily insert the seat post into the seat tube.

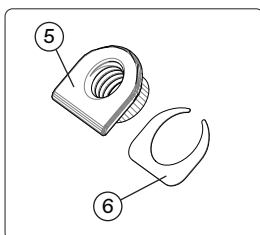
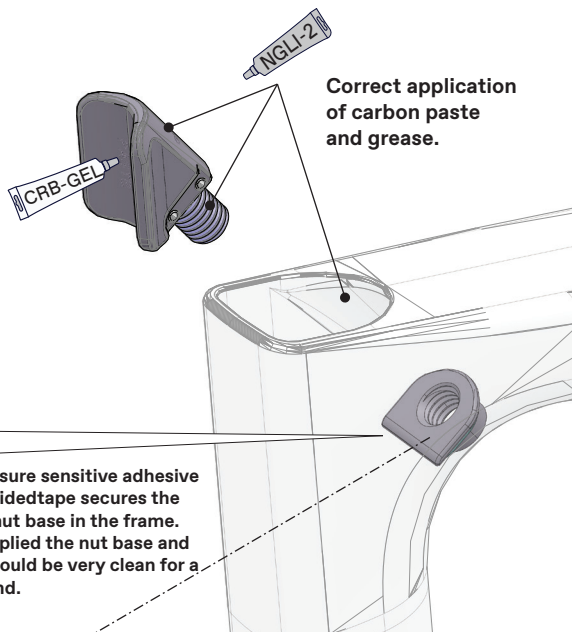
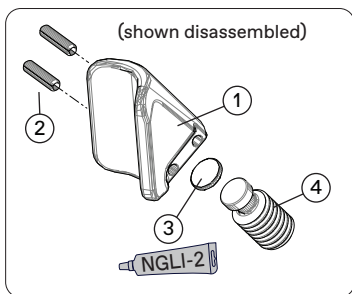

The pressure sensitive adhesive double-sided tape secures the aligned nut base in the frame. When applied the nut base and frame should be very clean for a good bond.

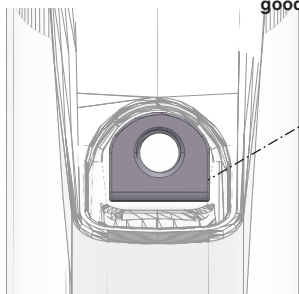

**This is CORRECT.**

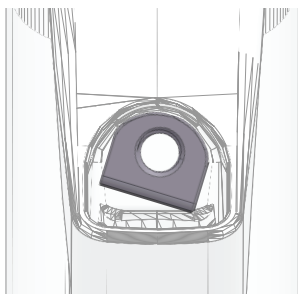

**This is INCORRECT.  
The nut plate is rotated.**

**Ready to accept seat post.**

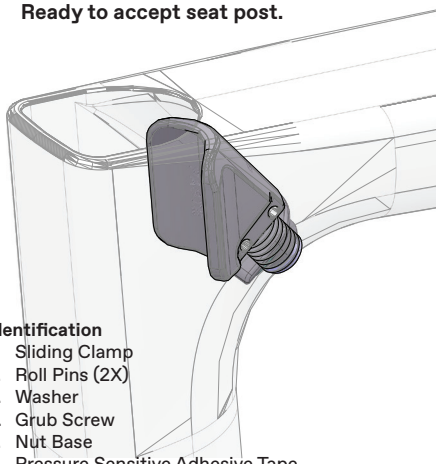

**Identification**

1. Sliding Clamp
2. Roll Pins (2X)
3. Washer
4. Grub Screw
5. Nut Base
6. Pressure Sensitive Adhesive Tape (Double-sided)

## KNØT Stem Spacers

Spacers can be flexed open to allow spacer assembly / disassembly without disconnecting cables.



Bend spacer inwards to route cables through first slot, then route cables through the second slot.



Assemble spacer on steerer tube.



Spacers and stem have interlocking feature to ensure alignment.



Hinge covers together and slide them over the stem body. Stem body and covers have interlocking features.



Close right stem cover first, then rotate left stem cover in place and close around the stem body



Assemble the stem covers with the M3 bolt (1Nm)



## REPLACEMENT PARTS

### Frame / Fork

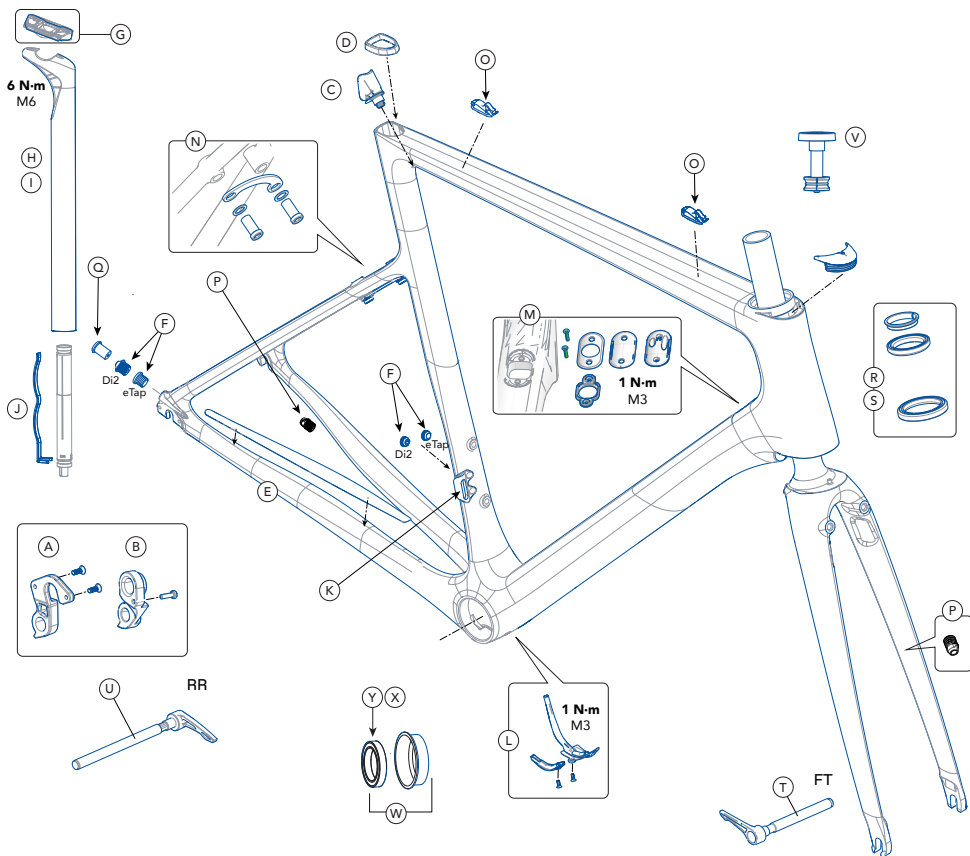

ID	Part Number	Description	DISC	RIM
A	KP255/	Derailleur Hanger QR ST SS 027		✓
B	K33009	Derailleur Hanger TA ST SS 070	✓	
C	K26030	S6 EVO Internal Seat Binder	✓	✓
D	K26070	Seatpost Silicone Grommet	✓	✓
--	KF115/	Carbon Seatpost Gel	✓	✓
E	K34140	Chainstay Protection Film	✓	✓
F	K32170	S6 Evo Grommets	✓	✓
G	K26050	KNOT 27 Rail Clamps and Hardware	✓	✓

ID	Part Number	Description	DISC	RIM
H	K2601000	HG 27 KNOT Crb Seatpost 330mm 0 O/Set	✓	✓
	K2601015	HG 27 KNOT Crb Seatpost 330mm 15 O/Set	✓	✓
I	K2602015	C1 27 KNOT Alloy Seatpost 330mm 15 O/Set	✓	✓
J	K32180	KNOT 27 Di2 Battery Mount	✓	✓
K	K33070	S6 EVO FD Hanger	✓	✓
L	K32150	S6 EVO BB Cable Guide	✓	✓
M	K32160	S6 EVO/CAAD13 Down Tube Cable Guide	✓	✓
N	K31000	Rim Brake Bridge		✓
O	K32010	Clip-in Brake Cable Stop QTY 2		✓
P	KP449/	Rubber Brake Housing Grommets	✓	
Q	K32330	Dropout Cable Stop (QTY 1)	✓	✓
R	K35028	1 1/4 Crb Headset No Crown Race	✓	✓
S	K35038	1 3/8 Crb Headset No Crown Race	✓	✓
T	K83019	Speed Release TA 100×12 2Lead P1.0 119mm	✓	
U	K83029	Speed Release TA 142×12 2Lead P1.0 165mm	✓	
V	K35059	SL Compression Plug with Top Cap	✓	✓
W	KP197/SRM	PF30 Bottom Bracket Cups And Bearings	✓	✓
Y	KB6180/	BB30 Bearing Blue (QTY 2)	✓	✓
X	K22037	BB30 Bearing Blue (QTY 24)	✓	✓

### KNØT / SAVE SystemBar (SuperSix EVO)

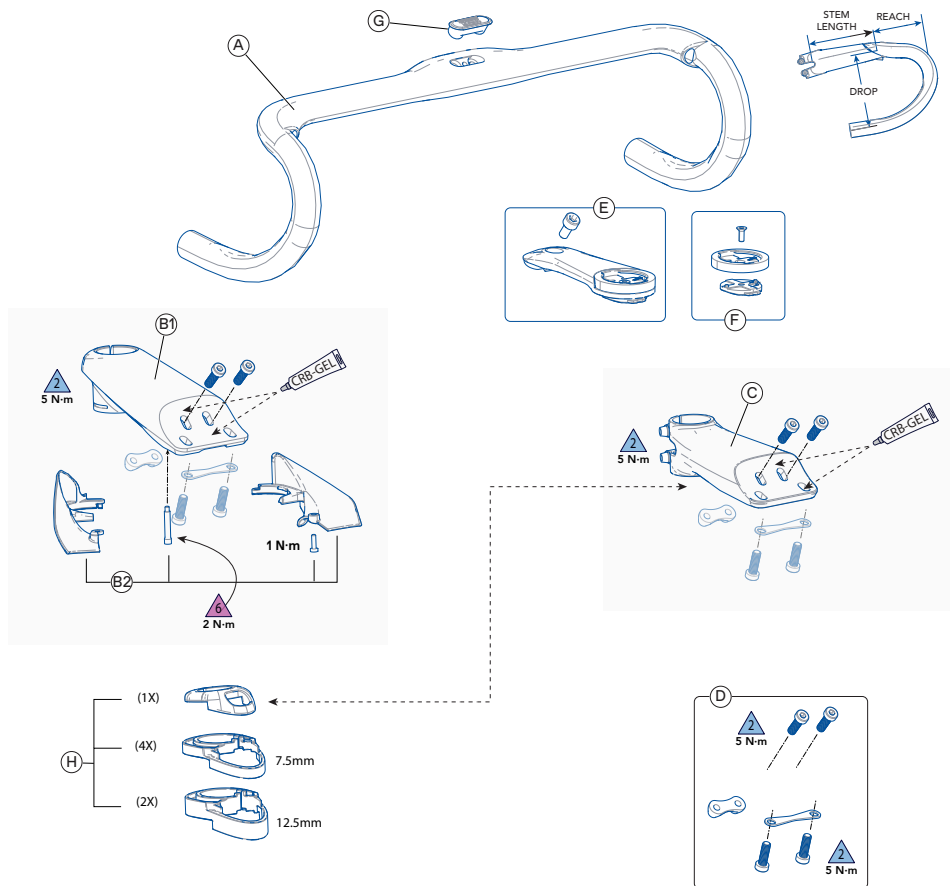

### KNØT & SAVE Shared Parts

ID	Description	Part Number
D	K28018	SystemBar Mounting Hardware
E	K12018	SystemBar Computer and Light Mount
F	K12008	SystemBar Computer and Light Insert
G	K28039	HGRM KNØT/SAVE Handlebar Plug
H	K28000	SuperSix Stem Spacers



## Handlebar

ID	Description	Part Number	Width (cm)
A	KNØT	CP2650U1038	38
		CP2650U1040	40
		CP2650U1042	42
		CP2650U1044	44
	SAVE	CP2600U1036	36
		CP2600U1038	38
		CP2600U1040	40
		CP2600U1042	42
		CP2600U1044	44

## Stems

ID	Description	Part Number	Stem Length (mm)	Stem Rise (degrees)
B1	KNØT Stems	CP2300U1080	80	- 17
		CP2300U1090	90	
		CP2300U1010	100	
		CP2300U1011	110	
		CP2300U1012	120	
		CP2250U1080	80	- 6
		CP2250U1090	90	
		CP2250U1010	100	
		CP2250U1011	110	
		CP2250U1012	120	
B2	SuperSix EVO KNØT Stem Covers	K2804080	80	- 17
		K2804090	90	
		K2804000	100	
		K2804010	110	
		K2804020	120	
		K2803080	80	- 6
		K2803090	90	
		K2803000	100	
		K2803010	110	
		K2803020	120	
C	SAVE Stems	CP2000U1080	80	- 6
		CP2000U1090	90	
		CP2000U1010	100	
		CP2000U1011	110	
		CP2000U1012	120	
		CP2000U1030	130	+ 6
		CP2100U1080	80	
		CP2100U1090	90	
		CP2100U1010	100	
		CP2100U1011	110	

## KNØT SystemStem

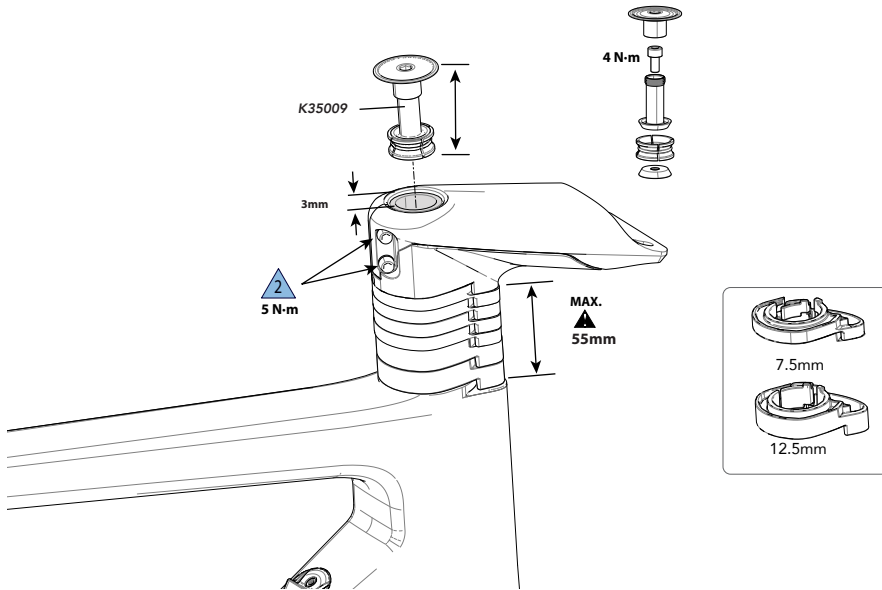

- The KNØT stem supports internal brake hose and Di2 wire routing.
- Assembly of spacers is explained on the previous pages.
- Stem height may be set using combination of the 12.5mm and/or 7.5mm spacers.
- The maximum spacer stack height is 55mm. The example above depicts 2x 12.5mm spacers and 4x 7.5mm spacers, resulting in 55mm.
- The KNØT stem is to be used only with a Cannondale SystemBar handlebar such as SAVE or KNOT SystemBar.
- Use only the Cannondale SI Compression plug **K35009**.

Additional instruction at:

<https://p.widencdn.net/w5njzq/134947-REV-1-CD-OMS-SAVE-KNOT-SystemBar>



WWW.CANNONDALE.COM

© 2019 Cycling Sports Group

SuperSix EVO Owner's Manual Supplement

137369 Rev. 1

**CANNONDALE USA**

Cycling Sports Group, Inc.  
1 Cannondale Way,  
Wilton CT, 06897, USA  
1-800-726-BIKE (2453)  
[www.cannondale.com](http://www.cannondale.com)

**CANNONDALE EUROPE**

Cycling Sports Group Europe, B.V.  
Hanzepoort 27, 7570 GC, Oldenzaal,  
Netherlands +41 61 4879380  
[servicedeskeurope@  
cyclingsportsgroup.com](mailto:servicedeskeurope@cyclingsportsgroup.com)

**CANNONDALE UK**

Cycling Sports Group  
Vantage Way, The Fulcrum,  
Poole, Dorset, BH12 4NU  
+44 (0)1202732288  
[sales@cyclingsportsgroup.  
co.uk](mailto:sales@cyclingsportsgroup.co.uk)